



SOLUCIONES DE SOPORTES PARA TV

LOS SOPORTES DE MONTAJE EN PARED PARA TV EQUIP[®] SON PRODUCTOS COMPACTOS Y RESISTENTES QUE GARANTIZAN UNA INSTALACIÓN CONFIABLE DE SU TV LCD/PLASMA. ESTOS SOPORTES SE ADAPTAN A LA MAYORÍA DE LOS MATERIALES DE PARED: LADRILLO, HORMIGÓN Y MADERA, LO QUE ES LA ELECCIÓN IDEAL PARA INSTALAR SUS PANTALLAS.

23"-43" SLIM TV WALL MOUNT BRACKET

Product N° - 650401

KEY FEATURES

- Max. Load Capacity: 25Kg
- Max. VESA: 200x200
- Ultra Slim profile for space saving
- Tool-free tilt adjustment
- VESA standards compliant

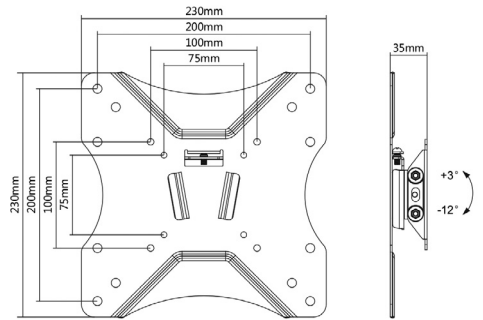

INSTALLATION VIDEO
SCAN HERE:



23"-42" PIVOTING TV WALL MOUNT BRACKET

Product N° - 650402

KEY FEATURES

- Max. Load Capacity: 25Kg
- Max. VESA: 200x200
- Adjustment knob enables a full range of tilt/swivel action
- VESA standards compliant
- Cable clips keep cables organized and protected

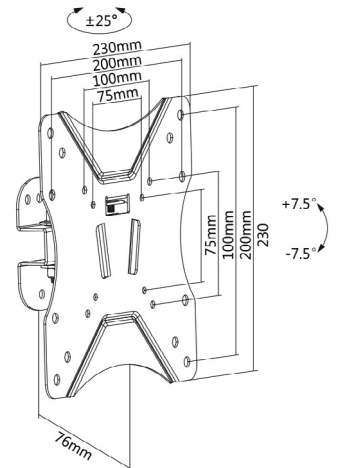

INSTALLATION VIDEO
SCAN HERE:



23"-55" ARTICULATING TV WALL MOUNT BRACKET

Product N° - 650405

KEY FEATURES

- Max. Load Capacity: 30Kg
- Max. VESA: 400x400
- Swivel and tilt wall mount
- VESA standards compliant
- Adjustment knob enables a full range of tilt action
- Free-tilting design for multiple monitor viewing angles
- Full motion mount

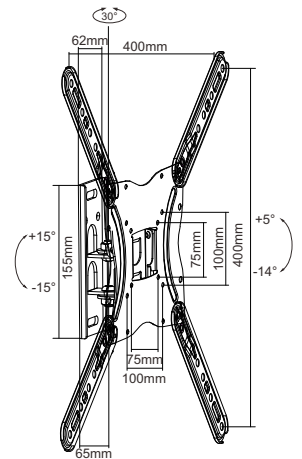

INSTALLATION VIDEO
SCAN HERE:



23"-55" PIVOTING TV WALL MOUNT BRACKET

Product N° - 650406

KEY FEATURES

- Max. Load Capacity: 30Kg
- Max. VESA: 400x400
- Full motion mount
- Adjustment knob enables a full range of tilt action
- Free-tilting design for multiple monitor viewing angles
- VESA standards compliant

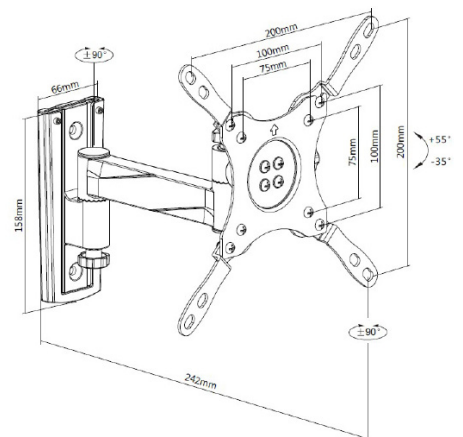

INSTALLATION VIDEO
SCAN HERE:



23"-55" ARTICULATING TV WALL MOUNT BRACKET

Product N° - 650407

KEY FEATURES

- Max. Load Capacity: 30Kg
- Max. VESA: 400x400
- Full motion mount
- Adjustment knob enables a full range of tilt action
- Free-tilting design for multiple monitor viewing angles
- VESA standards compliant

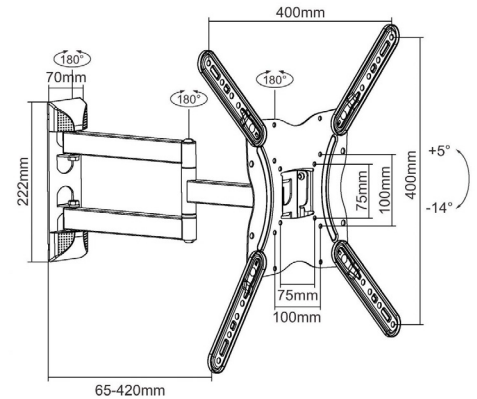

INSTALLATION VIDEO
SCAN HERE:



23"-43" TILT TV WALL MOUNT BRACKET

Product N° - 650408

KEY FEATURES

- Max. Load Capacity: 35Kg
- Max. VESA: 200x200
- Slide-in wall plate provides easy access for attachment and detachment
- Free-tilting design for multiple monitor viewing angles
- VESA standards compliant

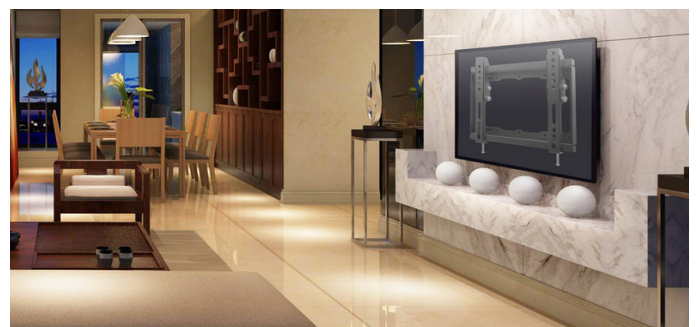
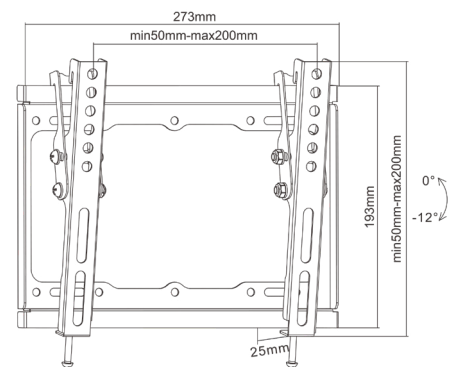

INSTALLATION VIDEO
SCAN HERE:



37"-55" FIXED TV WALL MOUNT BRACKET

Product N° - 650363

KEY FEATURES

- Max. Load Capacity: 55Kg
- Max. VESA: 400 x 400
- Integrated bubble level assures easy installation alignment
- Slide-in wall plate provides easy access for attachment and detachment
- VESA standards compliant

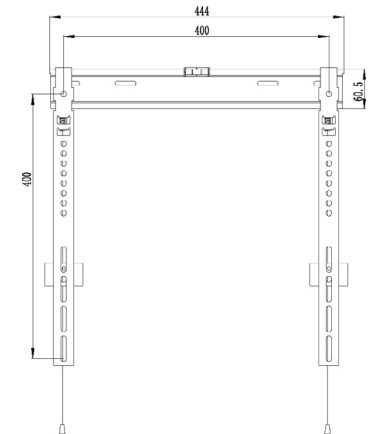

INSTALLATION VIDEO
SCAN HERE:

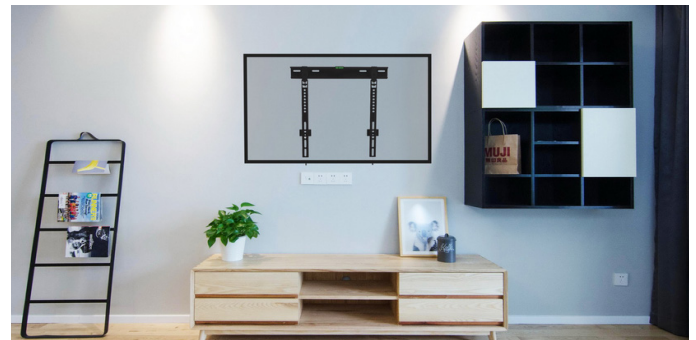

32"-55" FIXED TV WALL MOUNT BRACKET

Product N° - 650310

KEY FEATURES

- Max. VESA: 400x400
- Max. Load Capacity: 40Kg
- Slide-in wall plate provides easy access for attachment and detachment
- Integrated bubble level assures easy installation alignment
- VESA standards compliant

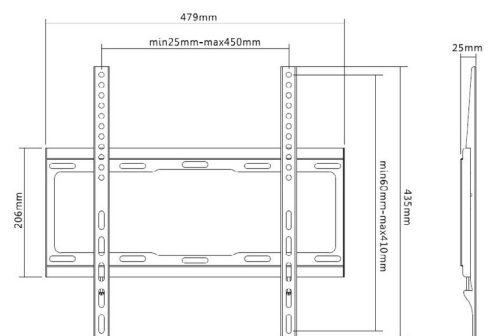

INSTALLATION VIDEO
SCAN HERE:

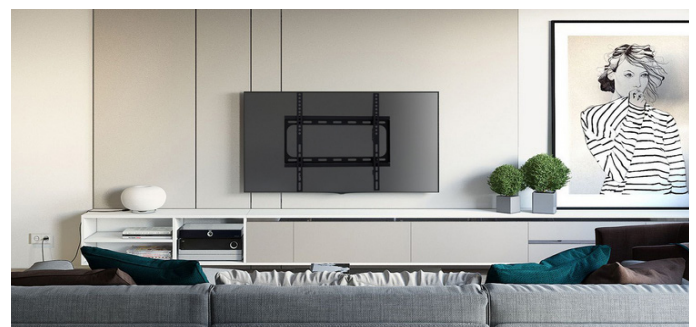

32"-55" TILT TV WALL MOUNT BRACKET

Product N° - 650311

KEY FEATURES

- Max. Load Capacity: 35Kg
- Max. VESA: 400x400
- Free-tilting design for multiple monitor viewing angles
- Slide-in wall plate provides easy access for attachment and detachment
- Integrated bubble level assures easy installation alignment
- VESA standards compliant

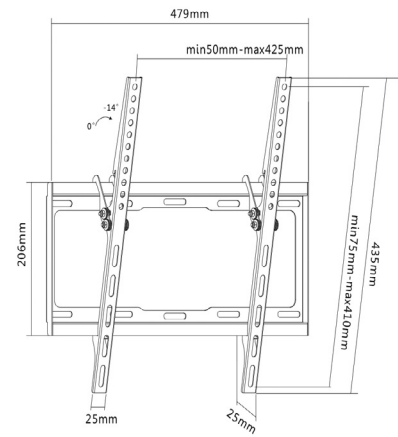

INSTALLATION VIDEO
SCAN HERE:



37"-70" FIXED SLIM TV WALL MOUNT BRACKET

Product N° - 650330

KEY FEATURES

- Max. Load Capacity: 40Kg
- Max. VESA: 600x400
- Slide-in wall plate provides easy access for attachment and detachment
- Integrated bubble level assures easy installation alignment
- VESA standards compliant

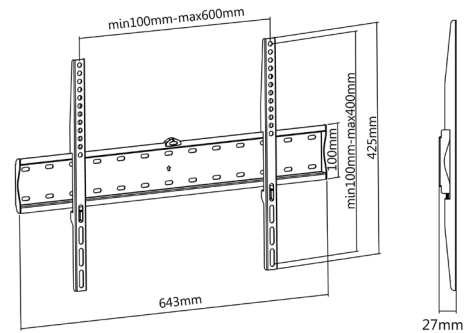

INSTALLATION VIDEO
SCAN HERE:



37"-70" FIXED TV WALL BRACKET

Product N° - 650333

KEY FEATURES

- Max. Load Capacity: 35Kg
- Max. VESA: 600x400
- Ultra-slim design
- Slide-in wall plate provides easy access for attachment and detachment
- Integrated bubble level assures easy installation alignment
- VESA standards compliant

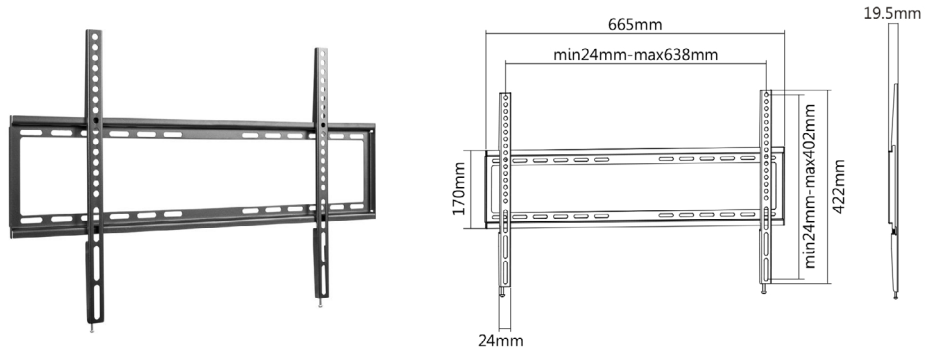

INSTALLATION VIDEO
SCAN HERE:



37"-70" TILT TV WALL BRACKET

Product N° - 650332

KEY FEATURES

- Max. Load Capacity: 40Kg
- Max. VESA: 600x400
- Slide-in wall plate provides easy access for attachment and detachment
- Integrated bubble level assures easy installation alignment
- VESA standards compliant
- Free-tilting design for multiple monitor viewing angles

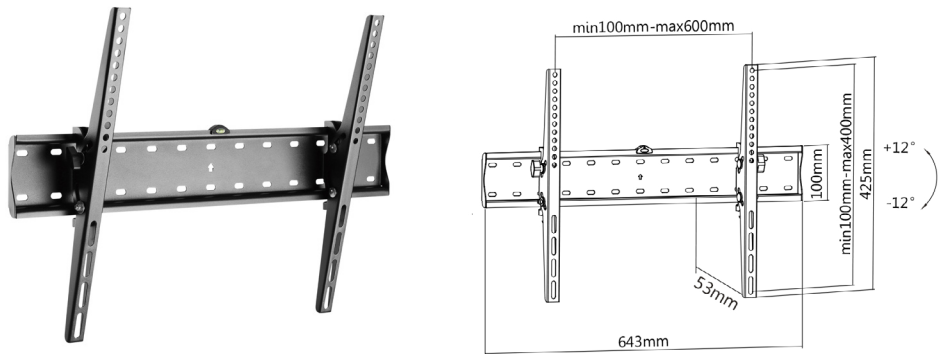

INSTALLATION VIDEO
SCAN HERE:



32"-55" ECONOMY SLIM TILT TV WALL MOUNT BRACKET

Product N° - 650319

KEY FEATURES

- Max. Load Capacity: 35Kg
- Max. VESA: 400x400
- Free-tilting design for multiple monitor viewing angles
- Ultra Slim profile for space saving
- VESA standards compliant

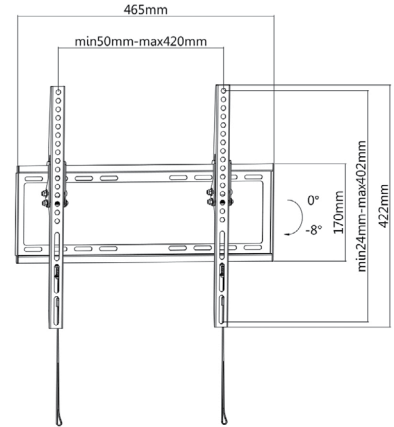

INSTALLATION VIDEO
SCAN HERE:



37"-70" LOW PROFILE TV WALL MOUNT BRACKET

Product N° - 650334

KEY FEATURES

- Max. Load Capacity: 35Kg
- Max. VESA: 600x400
- Ultra-slim design
- Integrated bubble level assures easy installation alignment
- Adjustment knob enables a full range of tilt action
- Easy-grip button for quick angling and locking
- VESA standards compliant

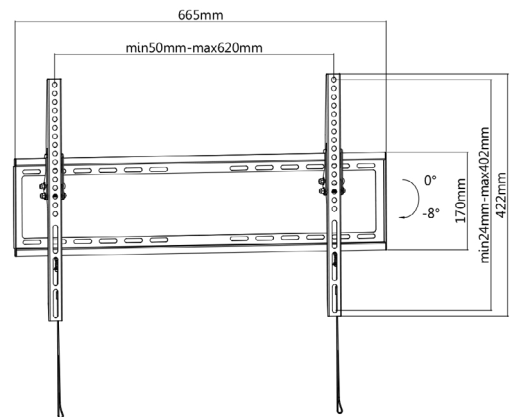

INSTALLATION VIDEO
SCAN HERE:



60"-100" FIXED CURVED TV WALL MOUNT BRACKET

Product N° - 650323

KEY FEATURES

- Max. Load Capacity: 100Kg
- Max. VESA: 900x600
- X-Large Heavy-duty Fixed Curved & Flat Panel TV Wall Mount
- Automatically click-in spring lock helps TV brackets snap into place
- VESA standards compliant

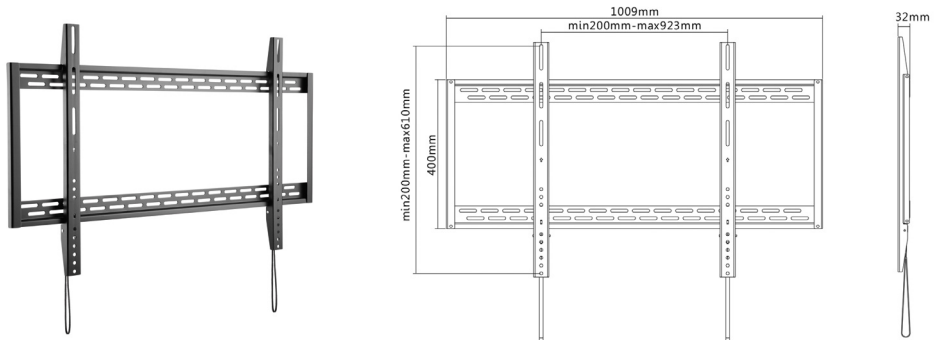

INSTALLATION VIDEO
SCAN HERE:



60"-100" TILT CURVED TV WALL MOUNT BRACKET

Product N° - 650322

KEY FEATURES

- Max. Load Capacity: 100Kg
- Max. VESA: 1000x800
- Free-tilting design for multiple monitor viewing angles
- Automatically click-in spring lock helps TV brackets snap into place
- Tool-free tilt adjustment
- VESA standards compliant

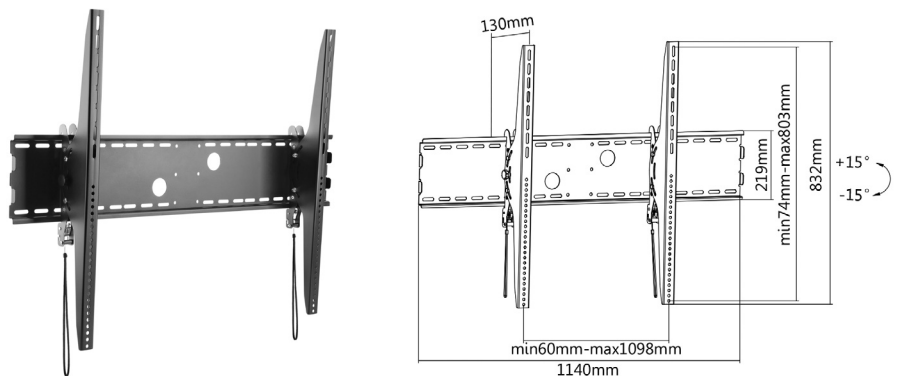

INSTALLATION VIDEO
SCAN HERE:



32"-55" ARTICULATING TV WALL MOUNT BRACKET

Product N° - 650315

KEY FEATURES

- Max. Load Capacity: 50Kg
- Max. VESA: 400x400
- Full motion mount
- VESA standards compliant
- Level adjustment ensures perfect positioning

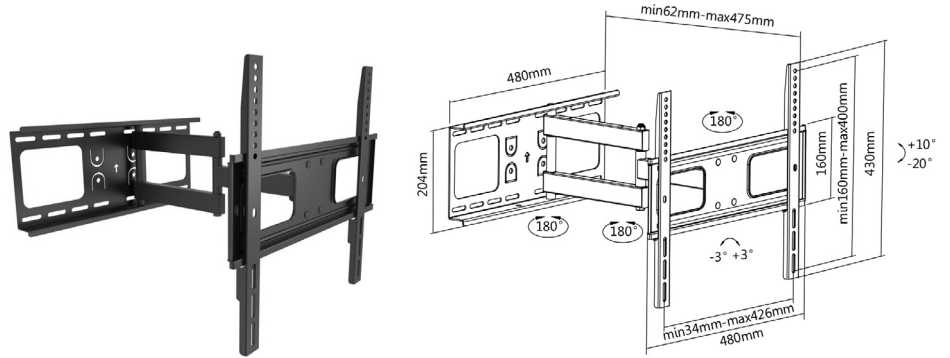

INSTALLATION VIDEO
SCAN HERE:



37"-70" ARTICULATING TV WALL MOUNT BRACKET

Product N° - 650316

KEY FEATURES

- Max. Load Capacity: 50Kg
- Max. VESA: 600x400
- Built-in level adjustment ensures perfect positioning
- VESA standards compliant
- Full motion mount
- Free-tilting design for multiple monitor viewing angles

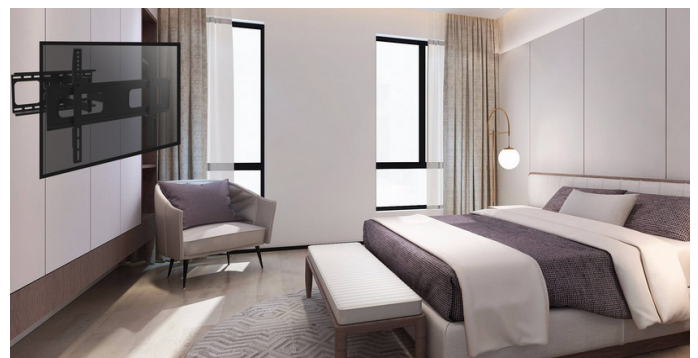
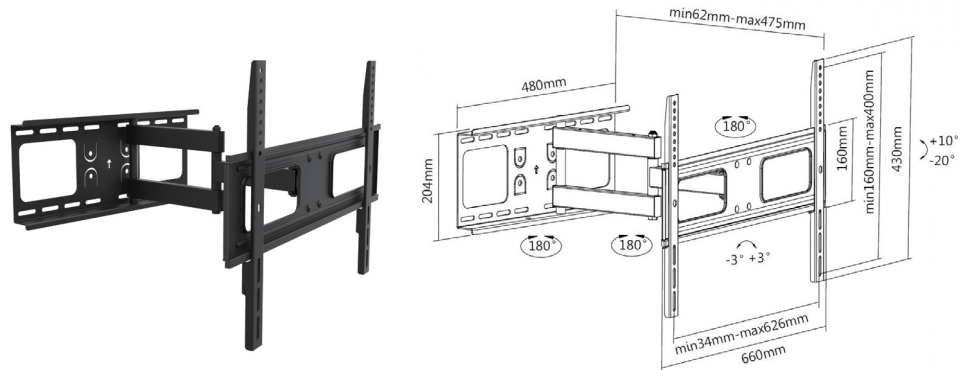

INSTALLATION VIDEO
SCAN HERE:



32"-55" ARTICULATING TV WALL BRACKET

Product N° - 650341

KEY FEATURES

- Max. Load Capacity: 35Kg
- Max. VESA: 400x400
- Full motion mount
- VESA standards compliant
- Free-tilting design for multiple monitor viewing angles
- Level adjustment ensures perfect positioning
- Build-in cable management

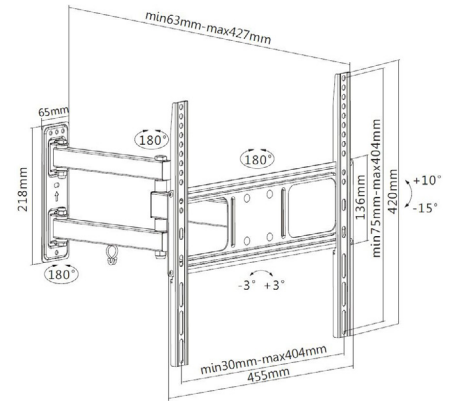

INSTALLATION VIDEO
SCAN HERE:



37"-70" ARTICULATING TV WALL BRACKET

Product N° - 650342

KEY FEATURES

- Max. Load Capacity: 35Kg
- Max. VESA: 600x400
- Full motion mount
- VESA standards compliant
- Free-tilting design for multiple monitor viewing angles
- Level adjustment ensures perfect positioning
- Build-in cable management

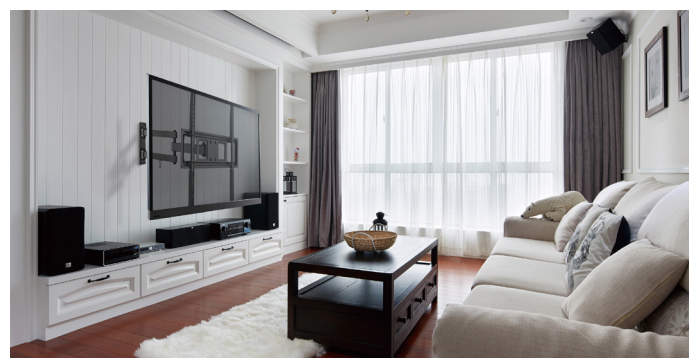
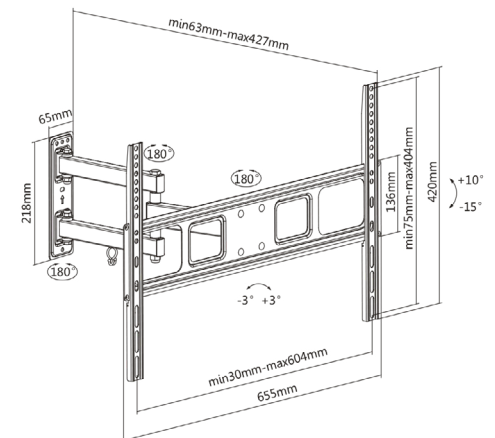
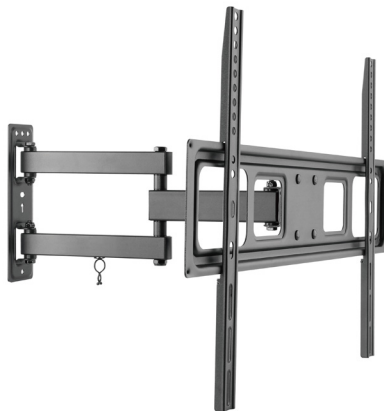

INSTALLATION VIDEO
SCAN HERE:



37"-90" TILT/SWIVEL TV WALL MOUNT BRACKET

Product N° - 650324

KEY FEATURES

- Max. Load Capacity: 75Kg
- Max. VESA: 800x400
- Swiveling arm offer maximum viewing flexibility
- Built-in level adjustment ensures perfect positioning
- Swivel and tilt wall mount
- VESA standards compliant

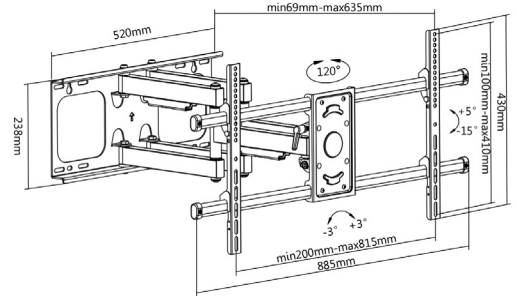

INSTALLATION VIDEO
SCAN HERE:



43"-70" PULL-DOWN TV WALL MOUNT

Product N° - 650326

KEY FEATURES

- Max. Load Capacity: 35Kg
- Max. VESA: 600x400
- VESA standards compliant
- Swivel and tilt wall mount
- Built-in level adjustment ensures perfect positioning
- Gas Piston Auto-Stabilization
- Cable Management: keeps everything organized

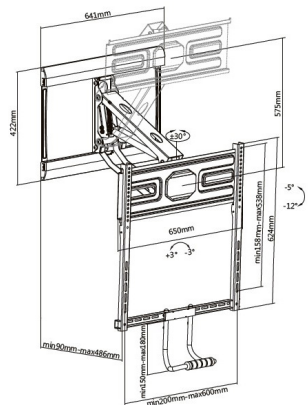

INSTALLATION VIDEO
SCAN HERE:



43"-80" LONG ARM FULL MOTION TV WALL MOUNT BRACKET

Product N° - 650327

KEY FEATURES

- Max. Loading capacity: 50kg
- Max. VESA : 800 x 400
- VESA standard compliant
- Swivel and Tilt wall mount
- Extending Arm: provides a wide range of viewing angles
- Quick-Release Latch: locks/unlocks the display in place
- Build-in Cable management

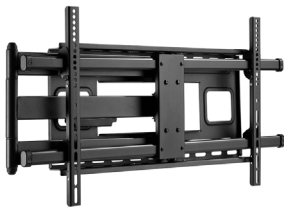
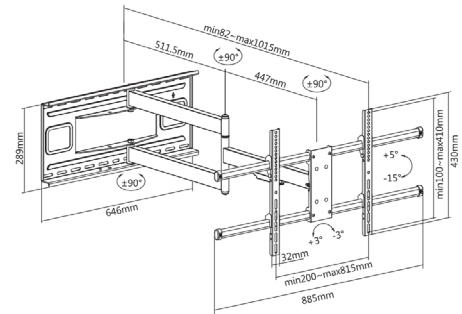

INSTALLATION VIDEO
SCAN HERE:



37"-80" FULL MOTION TV MOUNT BRACKET

Product N° - 650337

KEY FEATURES

- Max. Load Capacity: 40Kg
- Max. VESA: 600x400
- Swiveling arm offer maximum viewing flexibility
- Free-Tilting Design and reduced glare
- 2-Level adjustment ensures perfect positioning
- Swivel and tilt wall mount
- VESA standards compliant
- Cable clips keep cables organized and protected

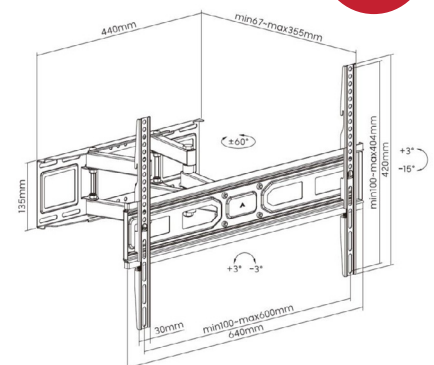

NEW



INSTALLATION VIDEO
SCAN HERE:



60"-120" HEAVY-DUTY FIXED TV MOUNT BRACKET

Product N° - 650338

NEW

KEY FEATURES

- Max. Load Capacity: 120Kg
- Max. VESA: 900x600
- Automatic Spring Locks with Quick Release Cords
- Heavy-Duty Steel Construction: provides extra strength and durability
- VESA standards compliant

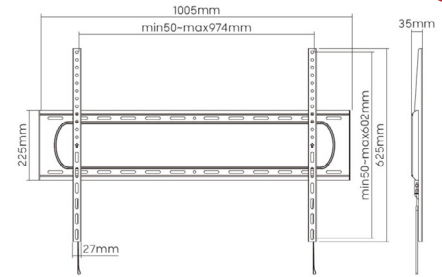
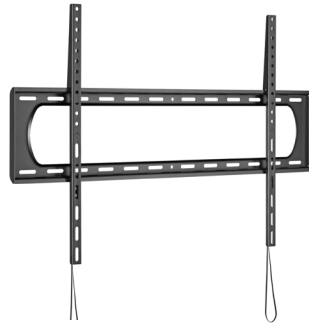

INSTALLATION VIDEO
SCAN HERE:



60"-120" HEAVY-DUTY TILT TV MOUNT BRACKET

Product N° - 650339

NEW

KEY FEATURES

- Max. Load Capacity: 120Kg
- Max. VESA: 900x600
- Automatic Spring Locks with Quick Release Cords
- Heavy-Duty Steel Construction: provides extra strength and durability
- Free-tilting design for multiple monitor viewing angles
- VESA standards compliant

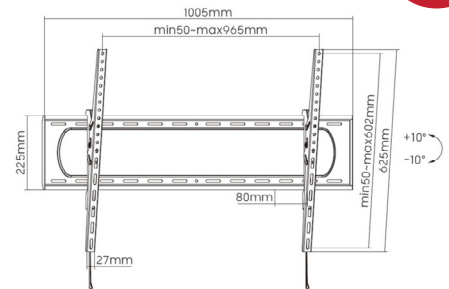

INSTALLATION VIDEO
SCAN HERE:



60-120" HEAVY-DUTY FULL MOTION TV MOUNT BRACKET

Product N° - 650343

NEW

KEY FEATURES

- Max. Load Capacity: 120Kg
- Max. VESA: 900x600
- VESA standards compliant
- Extending Arm: provides a wide range of viewing angles
- Swiveling Arm(s): offer(s) maximum viewing flexibility
- Quick-Release Latch: locks/unlocks the display in place
- Built-in level adjustment ensures perfect positioning
- Free-Tilting Design and reduced glare

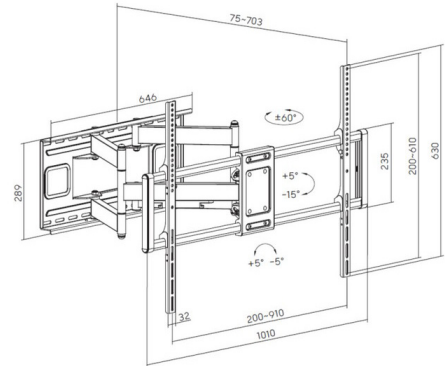
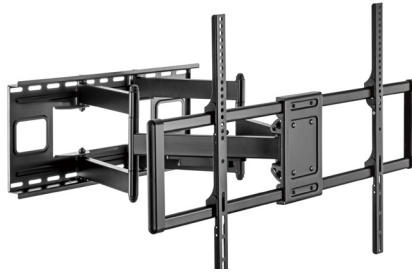

INSTALLATION VIDEO
SCAN HERE:



37"-65" MOTORIZED REMOTE CONTROL TV STAND

Product N° - 650606

KEY FEATURES

- Max. Load Capacity: 50Kg
- Max. VESA: 600x400
- VESA standards compliant
- Lift Design: create unique enclosures or cabinets to conceal TVs
- Height adjustment Integrated cable management
- Remote Control Included: for easy movements
- Strong lifting power with low noise level
- Powerful Motor: more stable, strong and durable

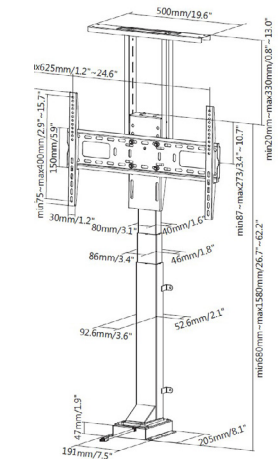
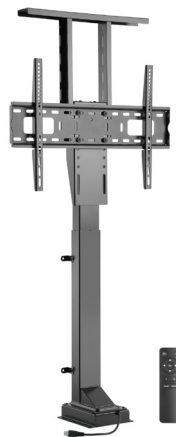

INSTALLATION VIDEO
SCAN HERE:



32"-75" MOTORIZED TV SWING MOUNT BRACKET

Product N° - 650336

KEY FEATURES

- Max. Load Capacity: 50Kg
- Max. VESA: 600x400
- VESA standards compliant
- Level adjustment ensures perfect positioning
- Built-in Cable management
- Powerful Motor: more stable, strong and durable
- Remote Control Included: for easy movements
- Collision Avoidance System: safeguards against accidents and injuries
- Low profile: 56mm extra slim design
- Programmable Position Memory Function records the position you like

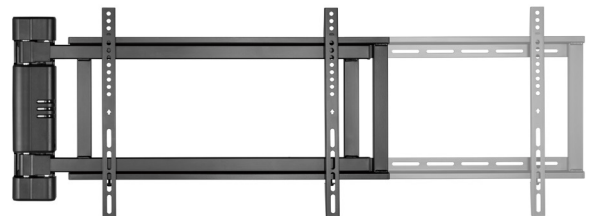
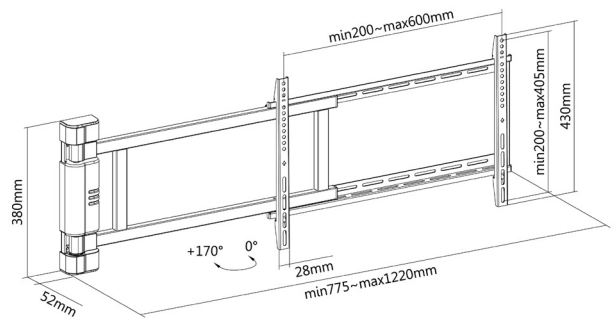
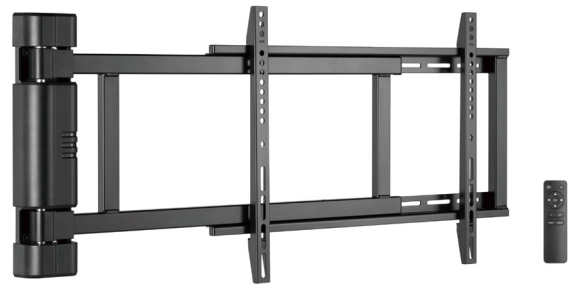

INSTALLATION VIDEO
SCAN HERE:



23"-55" FULL MOTION CORNER TV WALL MOUNT BRACKET

Product N° - 650328

KEY FEATURES

- Max. Load Capacity: 45Kg
- Max. VESA: 400x400
- VESA standards compliant
- Split Wall Plate: works on different angled corner walls and save space (also can be installed on flat wall)
- Free-tilting design for multiple monitor viewing angles
- Built-in level adjustment ensures perfect positioning
- Build-in cable management

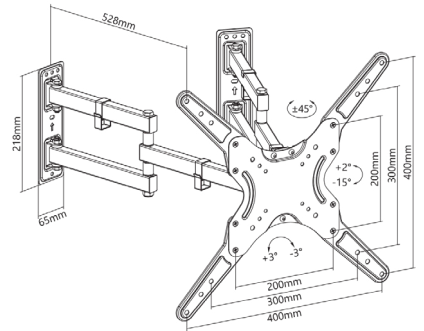

INSTALLATION VIDEO
SCAN HERE:



37"-80" FULL MOTION TV WALL MOUNT BRACKET

Product N° - 650335

KEY FEATURES

- Max. Load Capacity: 60Kg
- Max. VESA: 600x400
- Swiveling arm offer maximum viewing flexibility
- Built-in level adjustment ensures perfect positioning
- Swivel and tilt wall mount
- VESA standards compliant
- Build-in cable management

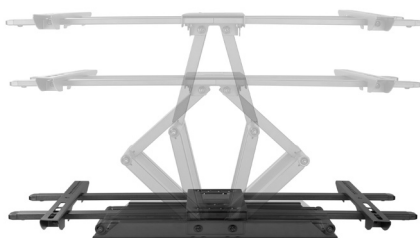
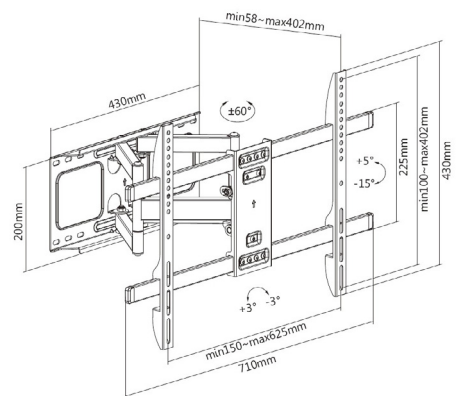

INSTALLATION VIDEO
SCAN HERE:



37"-80" UNIVERSAL ROTATING WALL BRACKET

Product N° - 650331

KEY FEATURES

- Max. Load Capacity: 50Kg
- Max. VESA: 600x400
- VESA standards compliant
- Portrait or Landscape viewing : one solution fits any installation
- Slide-in wall plate provides easy access for attachment and detachment
- Quick-Release latch: locks/unlocks the display in place
- Magnetic strap end : hides itself when not in used

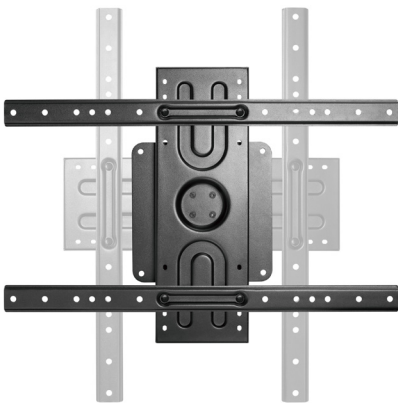
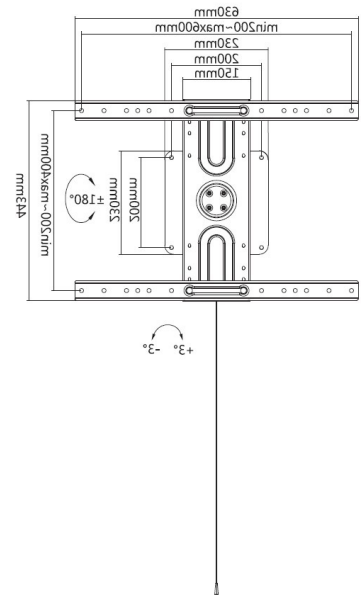

INSTALLATION VIDEO
SCAN HERE:



UNIVERSAL SOUNDBAR MOUNT

Product N° - 650895

KEY FEATURES

- Max. Load Capacity: 15Kg
- Applicable Device size: Soundbar (Width: 86~155mm)
- High Compatibility: support most any popular devices
- EVA padded base prevents vibration noise
- Anti-fall hooks firmly secure the soundbar
- One-fit-all design makes mounting the soundbar above or below the TV

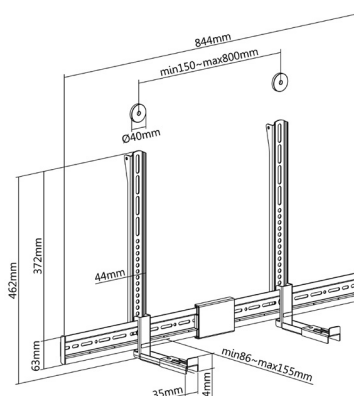

NEW

INSTALLATION VIDEO
SCAN HERE:



UNIVERSAL MEDIA PLAYER MOUNT

Product N° - 650896

KEY FEATURES

- Max. Load Capacity: 1Kg
- Applicable Device size: (32-46MM width)
- Open Construction design
- Rotary Knob Design: for easy assembly or adjustment

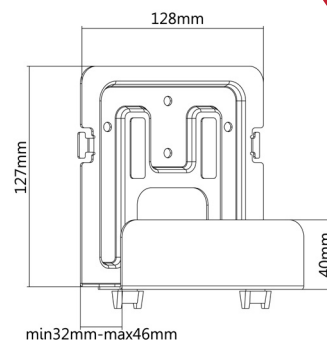

NEW

INSTALLATION VIDEO
SCAN HERE:





www.equip-info.net



Technical specifications are subject to change without notice.
© Copyright Digital Data Communications GmbH. All Rights Reserved.
Im Defdahl 10F, 44141 Dortmund, Germany

DISTRIBUTED BY

2024 EN